

LEVERAGING STUDENT DESIGN EXPERIENCE THROUGHOUT THE CURRICULUM USING CASE STUDIES

Steve LAMBERT and David EFFA

Waterloo Cases in Design Engineering, Faculty of Engineering, University of Waterloo,
Waterloo, Ontario, Canada

ABSTRACT

While the pedagogical benefits of student design teams are well established, participation is limited by available resources and the level of commitment of each student team member, since participation is predominantly extra-curricular. As a method to leverage this design experience to other students and to help promote the design teams themselves, case studies are proposed. They can be developed from student competition team design experience, and used in classes throughout the curriculum. An example case study on energy storage design is presented, based on the EcoCAR Challenge competition. This has been used in two separate first year engineering courses, in two departments, either as a term-long project or a guest lecture. Students found this an engaging introduction to engineering design, which benefited from the fact that this project was derived from their colleagues' experience.

Keywords: Case studies, design education, engineering practice, design teams

1 INTRODUCTION

Student competition teams offer an exceptional learning experience to those students who participate directly. They offer a realistic engineering environment where technical excellence is required, and tested. As such, they are an excellent venue for making connections between theory and practice. Many of these competitions revolve around the design, building and testing of a prototype vehicle. Example student vehicle competitions include Formula SAE, Mini Baja, Solar Vehicle, and the EcoCar Challenge. The scale of these projects is such that they require students to form and run their own engineering teams to successfully compete. This scale also means that it is often difficult to fit this participation into the undergraduate curriculum, and many students participate on an extra-curricular basis only, although many also can use this experience as their capstone design project requirement.

A typical student team provides a rich engineering experience, in a situation where the goals are challenging and the constraints are real. The competitive environment adds an additional layer of motivation, so that students are more fully engaged and learning is maximized. Many Universities recognize this benefit, and provide facilities and support to their teams. These could include supplementary training, access to facilities and technical staff, and financial support. It is desirable to further leverage this support, and to extend some of this learning to other students. One way of doing so is to develop case studies from student competition team design experience, and to use these in various ways across the curriculum.

A case study is a description of an engineering challenge [1, 2], and may include a solution. Case histories, for example of engineering failures [3], are an example of a case with a solution. In the present context, attention will be paid to cases which present only the problem. Even though a solution may exist, they would not typically be given to the students a priori, but provided to the instructor for reference and to provide supplemental information to be released selectively to students as they solve the problem. The actual solution may be shown to the students at the end of the project as a form of closure.

Waterloo Cases in Design Engineering (WCDE) is a group within the Faculty of Engineering that produces case studies for use throughout the Curriculum, to demonstrate engineering science and design principles. The focus of this group is the generation of case studies from our students' co-op work term experience [4]. This work is complemented by cases generated from other sources, including from student teams.

2 EXAMPLE CASE STUDY

The EcoCAR competition is a North American competition open by invitation only to Universities in the United States and Canada [5]. This competition is unique in that it operates over a three-year competition cycle, divided into annual stages corresponding to bench top testing and preliminary design; design and development of a working prototype; and finishing with the design and development of a more refined prototype, closer to consumer acceptance. Along with this extended timeline, the competition also has rigorous reporting and analysis requirements, and strong sponsor support; the title sponsor, General Motors (GM), provides a mentor for each team, for example. The primary objective of the competition is to significantly reduce fuel consumption and emissions for a 2008 Saturn VUE, by exploring advanced technological solutions. The goal is to increase energy efficiency while maintaining vehicle performance, safety and utility. There were many potential vehicle architectures considered by the various competition teams. Our team chose to build a hydrogen fuel cell electric hybrid vehicle.

The case study presented the background to the competition and explained the rationale for the choice of this particular architecture. This was a complex decision, based on detailed order of magnitude calculations to evaluate the various options. The hydrogen fuel cell vehicle offered the greatest reduction in petroleum energy use, although it had a significant disadvantage in vehicle range. Once the architecture was established, detailed power and energy calculations were made to specify the important powertrain components including the fuel cell system (FCS), front and rear electric motors, power electronics (bi-directional DC/DC converter), hydrogen storage system (HSS), and the Lithium Ion energy storage system (ESS). In the case study, critical parameters for each of these systems are provided, and the general problem that is given is the need to further refine each component. This provides the flexibility to use the case in a wide range of courses, including mechanical, mechatronics, electrical, and/or chemical engineering.

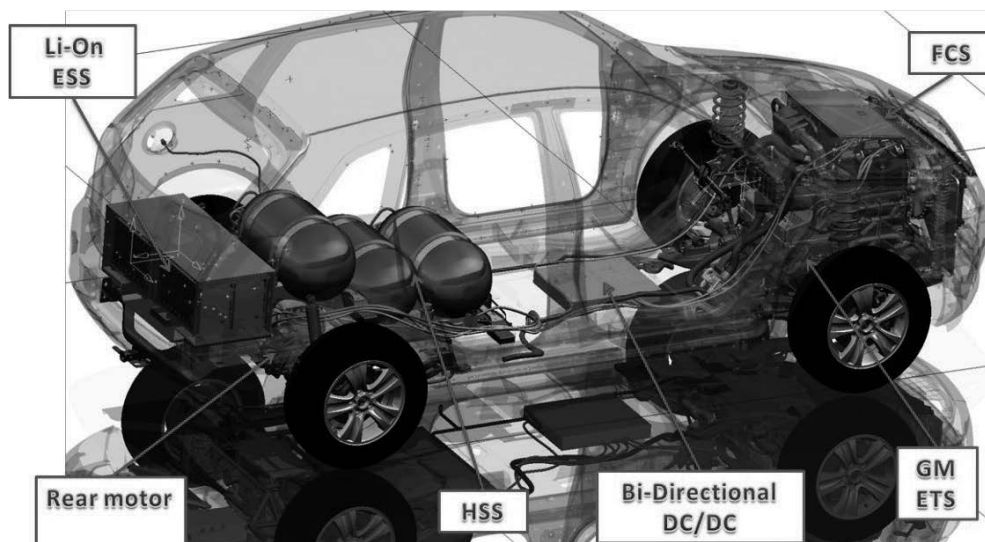

Figure 1. EcoCar vehicle architecture: hydrogen fuel cell hybrid electric vehicle

In the particular implementations to be discussed herein, the focus is on the design of the energy storage system. Since the target audience was first year students, there was a desire to significantly constrain the problem to limit the range of potential solutions so that students could be carefully guided through the design process. Therefore, the actual energy storage system chosen by the team, Figure 2, was provided to the students in a separate project statement. It was stated that this solution used few large modules specifically designed for automotive use, and the final configuration was significantly constrained by the available options from a competition sponsor; a more elegant solution

might be feasible if the battery pack was built up of much smaller separate cells. The chosen solution was thus provided as a benchmark, and enabled the students to clearly see the requirements for the ESS including nominal voltage, minimum voltage, energy and power requirements, and physical limitations on size (Figure 3) and weight. This also highlighted the importance of successive refinement in the design process.



Figure 2. Selected energy storage system

414 mm

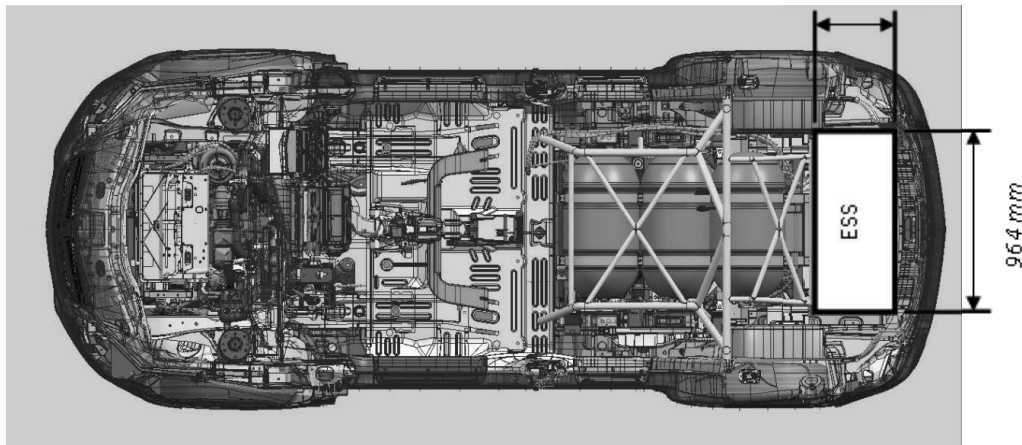

Figure 3. Spatial constraints on energy storage system

2.1 Case Implementations

This case study was used in a similar way in two different courses. Both classes were asked to design an alternative ESS, but the scope was significantly different. In a first year introduction to mechanical engineering and professionalism course, this case formed the basis for a term-long project. This project has the objectives of introducing students to the engineering design process, in the context of a real mechanical engineering project, while providing practice in presenting engineering analyses in a formal report. The second application was as a brief overview of the engineering design process, undertaken in a single lecture period.

The case implementation in the Mechanical Engineering course was intended as an intensive introduction to the profession: the design process, the engineering method, engineering calculations, and the effective presentation of engineering results, culminating in a major formal report. Students were introduced to the case early in the term, and were walked through the design process week by week, with regular assignments tied to the case. To place more focus on the mechanical engineering components, students were asked to perform energy and power calculations to determine the requirements for the energy storage system as a result of various driving scenarios. Once these requirements were set, they then proceeded to design the battery topology, a combination of identical cells in series and parallel, and to package them into the space available. Students were required to present and justify their final configuration using a combination of freehand sketches and CAD drawings. Students worked in groups to perform the calculations and come up with the final design, but were then required to submit individual reports. This project therefore served to integrate most of the topics in this course. Although students were asked for weekly feedback on the course and filled out end of term course evaluations, no survey specific to the case study was completed.

By comparison, the implementation in Electrical and Computer Engineering was restricted to a single lecture period. Students were asked to read the case the previous week and to answer a simple set of questions, which focused on their comprehension of the case material. This was done to ensure that they had read the case and were better prepared for the discussion the following week. During the lecture hour, the case was introduced and important elements of the design process were presented. Students were asked to form informal groups and to perform some of the simple calculations in class, for the number of strings of batteries in parallel that would be necessary to meet each of the given requirements on energy and power. And then the resulting configuration was presented, making use of some of the CAD images, Figure 4, generated by a group in the Mechanical Engineering class.

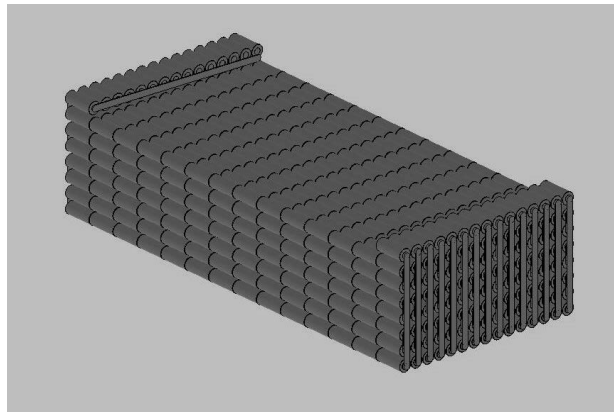

Figure 4. Example physical configuration of the ESS from one of the mechanical engineering groups

3 DISCUSSION

It is common in the mechanical engineering course to use an integrating project. This helps to tie together the assignments which cover the rudiments of engineering analysis with Excel, and the effective presentation of results. This also gives students the opportunity to work with their classmates in groups. It has been found that a more realistic problem statement is more effective, since it is easier to justify what sometimes appear to the students as arbitrary decisions to limit the scope of the project. In this situation, not only did we base the project on a real design problem, but we were also fortunate to have a key team member as one of our 4 full time undergraduate teaching assistants. This student was able to confidently respond to any technical issues brought up by the student groups, and vet any project decision made by the instructors for authenticity.

Students found the project engaging and were able to see the real-world application of the otherwise relatively dry material they were studying. At the same time, real problems are inherently complex. The students were exposed to this complexity in a controlled environment, but still got hung up on some of the details, for example the difference between peak and continuous power requirements. Students had to use simple electrical engineering concepts, Ohm's Law, and Kirchoff's law for simple series and parallel circuits. There was relatively little pushback from these mechanical engineering students, perhaps because they could see how this fit into the larger picture, and their role was focused on the more mechanical aspects of this: calculation of energy and power from fluid mechanics principles, and packaging.

The implementation in the Electrical and Computer Engineering course was as a guest lecturer for one 50 minute class. A study plan was presented to and approved by the instructor. It focused on giving an overview of the design process with a real-world example which would be relevant to these students. The specific learning outcome was for the students to see the value in the use of simple engineering models in the design process, in this case a simplified equivalent circuit to model the internal resistance in a battery. Students were expected to spend about 30 minutes in the week before class to review the material and answer some simple comprehension questions. The in-class period was divided into an introductory lecture, 2 group calculations, and class discussion of the design process. The pre-class work was treated as a class assignment worth 10 marks; it was completed by over 70%

of the students and the average mark was 9.5/10. The self-reported preparation time, including the quiz, varied from 7-65 minutes with an average of 32 minutes.

This case project was highly constrained in that there was really only one viable configuration given the various constraints. This was useful as it was a natural extension of the closed problems the students were used to, but with a more natural context. This meant that class discussion was focused on the answers and questioning the simplifications and assumptions used. The real-world context did however allow for discussions of less technical issues such as vehicle performance, customer expectations, and safety.

Students were asked to complete an online survey following completion of the in-class presentation, which was worth one mark. Twenty one students responded out of 124 in the class. Students were asked to list the course topics covered in this discussion. The top 4 responses were design, circuit analysis, battery technology and alternate energy. The majority of students found the case engaging, with 81% either agreeing or strongly with the statement that the case was “an engaging application of these course topics”. When asked why, some of the responses were: “Real-life application of theory”, and “Able to visualize real-life implementation of an engineering project with limitations and the procedures it had to go through prior to validation and testing.” Seventy six percent of students either agreed or strongly agreed with the statement that the “case helped me to understand the course material”. Clarifications included: “Reminder of Ohm’s Law”, “Interactive environment with classmates and dealt with constraints and calculations of typical engineering project”, and “Learned how to make a model to verify engineering design.”

Students were also asked to rate the small-group and class discussions. Sixty two percent of students agreed or strongly agreed with the statement that the “small group discussions helped me to understand the course material”. Of this group, reasons included: “Help with calculations”, “confirm answers”, “allowed for communication with other engineers similar to how it works in a real engineering team”, and “much easier to understand course topics when we discuss them in groups.”

For those students who strongly disagreed, disagreed or were neutral, reasons included: “Didn’t engage in discussions”, and “easy calculations.”

Similar results were obtained for the class discussions, with 62% agreeing or strongly agreeing that they were useful. Comments included: “Others ask better questions”, “know what others thought”, “broadened my view when ideas were shared”, and “solidified topics.”

Students were asked what they particularly liked about this case and why. Representative responses are provided in Table 1. Students liked the real-world aspects of the case, and being able to see the relationship between theory and practice. It was gratifying to also see the recognition of the need for effective communication, and the desire to see how these students might work with other engineers. Table 2 presents selected responses to students’ dislikes. These were focused on the relative simplicity of the calculations (consciously selected to allow a demonstration of the design process), and a desire to focus more narrowly on their own specialty. It is hoped that more experience and more exposure to multidisciplinary cases will help these students to appreciate the need to work with others, both engineers and non-engineers.

These responses are consistent with other experience, with cases written directly with industry. For instance, a case on brake design was used in a fourth year machine design course [6]. Students were asked to work in groups to design a brake for a heavy off-road vehicle, respecting both the company and international standards. Students found the case an intriguing application of theory, found it useful to work in groups to derive a solution, but at the same time were confused by incomplete and conflicting information. Much of the problems stemmed from the different terminology used and the different ways to present similar information. The instructor found even the negative comments reassuring, indicating that students were grappling with ways to tackle the real-world complexity of engineering problems.

Table 1. Selected student response to the question: “What did you particularly like about this case?”

What did you like	Why?
I enjoyed the aspect of applying data collecting and seeing how it applied to the topic at hand	it helps to see the connection between possible problem application and how to tackle the problem

Seeing how electrical and mechanical engineers work together	Nice seeing teamwork among engineers
Well it was nice to see a field application of what we learn in the lectures to get a feel of how typical industrial design projects take place.	I like to see Engineering work in the field rather than always being theoretical.
Emphasizing the need to communicate with the rest of the design team in different design areas.	Not everyone realizes communication is a BIG part of design

Table 2. Selected student response to the question: "What did you particularly dislike about this case?"

What did you dislike	Why?
None	I liked all of the activities and discussions.
It was not related to my field of comp eng.	It was unrelated to my interests.
Calculation of the String of Batteries	simple calculations that were not necessary to the understanding of what was happening
Some stuff is not really relevant	As ECE we don't need to know mechanical stuff

4 CONCLUSIONS

A case study developed from a student competition team project was used to teach engineering design in first year mechanical, and electrical and computer engineering courses. Students found the case engaging and enjoyed the chance to see a direct connection between theory and practice. Some were able to see the need for clear communication and the benefits of working with others outside their field. At the same time, some students' attitudes suggest that more work is required for them to see these benefits.

REFERENCES

- [1] J. N. Jensen, "A Case Study Approach to Freshmen Engineering Courses", Proceedings of the 2003 American Society of Engineering Annual Conference & Exposition, Nashville, Tennessee, June 22-25, 2003.
- [2] P.K. Raju, C. S. Sankar, Gerald Halpin, and Glennelle Halpin, "An Innovative Teaching Method to Improve Engineering Design Education", Proceedings of the 2000 American Society of Engineering Annual Conference & Exposition, St. Louis, Missouri, June 18-21, 2000.
- [3] H. Petroski, "To Engineer is Human: The Role of Failure in Successful Design", Vintage Books, 1992.
- [4] S. Lambert, C. Campbell, and O. Nespoli, "Leveraging Student Co-op Design Experience Using Case Studies", International Conference on Engineering and Product Design Education, Universitat de Catalunya, Barcelona, Spain, 4-5 September, 6 pages (2008).
- [5] EcoCAR Challenge, <http://www.ecocarchallenge.org/>, accessed March 1, 2012.
- [6] O. Nespoli, H. Tempelman, R. Spencer, and S.B. Lambert, "Disk Brake Design Case Study Implementation Method and Student Survey Results", Proceedings of the 2011 American Society of Engineering Education Annual Conference & Exposition, Vancouver, British Columbia, 26-29 June, 2011.