

## PATTERNS OF DESIGN AND DEVELOPMENT IN ADAPTIVE DESIGN: HOW DO WE MATCH DESIGN METHOD TO DESIGN CIRCUMSTANCE?

**C. A. McMahon**

University of Bath  
Department of Mechanical Engineering  
e-mail: c.a.mcmahon@bath.ac.uk

**C. Draper**

Mayflower Aerospace, UK

**Keywords:** Adaptive design, computer-aided design, knowledge-based engineering

**Abstract:** *Engineering effort is often concentrated on established design patterns. Within these patterns, knowledge develops through research, innovation, experiment and test. The paper first describes patterns of development in incremental design, including changes in customer demands and design constraints, in understanding of the relationship between the design performance and design attributes, and in understanding of the uncertainty in such relationships. Guidelines are then developed concerning the choice of the changes that develop the design, with the aim of allowing organisations to judge where to devote research and development effort and when to adopt more or less radical product design strategies. The level of design support and automation that may be possible through computer-aided design tools is then discussed, based on a spectrum of stages of development of knowledge in design.*

### 1. INTRODUCTION

The design of most engineering artefacts is based on that of previous artefacts of the same type. Indeed, in much of engineering, effort is concentrated on the development of broadly standard design patterns – consider for example the design of buildings, bridges, electrical equipment, production machines, engines and vehicles of all descriptions. Engineering knowledge develops through innovation and experiment in design, and through research, development and test programmes. Given that much product development occurs in such patterns, engineering organisations need guidelines concerning the size, frequency and direction of the changes that develop the design. Such guidelines will allow organisations to judge where to devote research and development effort, and when to adopt more or less radical prod-

uct design strategies. Knowledge of the likely areas in which product development will be most dynamic will also allow an organisation to choose the level of design support and automation that may be possible through computer-aided design tools. This paper will address each of these issues by presenting two points of view on the nature of engineering knowledge. It will firstly describe patterns of development in adaptive design, with a view to providing guidance on where to devote development effort. It will then describe a spectrum of stages of development of knowledge in design, and the match of design tool to this spectrum, with a view to providing guidance on the selection of design tool most appropriate to the stage of knowledge.

## 2. ADAPTIVE DESIGN

In many design domains engineering effort is concentrated on designs that are broadly conceptually static at an overall system level. Various terms are used to describe this: Pugh [1] actually uses the phrase “conceptually static design”, while Vincenti [2] and Constant [3], in their studies of historical developments in aerospace engineering, use the term “normal design” to reflect the wide prevalence of the genre. It is largely equivalent to the adaptive design mode described by Pahl and Beitz<sup>1</sup> [4], and, in view of the widespread use of those authors’ terminology, we will adopt the term “adaptive design” here. In such design, the overall solution principle used remains largely static with time but changes take place at subsystem and detail level as time progresses.

In many engineering domains the preferred design solution may be traced back to some particularly influential artefact that established a design pattern – for example the Fordson tractor, the IBM-PC or the Douglas DC-3 aircraft. Sahal [5] terms these design patterns “guideposts”, and he and others suggest that the growth of engineering knowledge is often concentrated on the growth of understanding of the behaviour of such design patterns, in particular from the process of scaling or patterning of the design – for example to improve its performance or increase its size or capacity. The design is seen by some as evolving [6][7], in particular in response to changes in the “demands” placed on the design by the customer (for example for improved performance or safety), and within limitations imposed by “constraints” which arise from the environment in which the design exists. The environment comprises such factors as available manufacturing processes and materials, constraints imposed by the circumstances in which the product will be used, such as dimensional requirements for aircraft imposed by airports, and also computing resources, human factors and so on.

### 2.1 Design dynamics

Of particular importance in design is the path of best performance. Designers try to develop products which are up to or ahead of the “state-of-the-art” in performance, cost, reliability and so on. To do this it is necessary to record understanding of the trajectory of design parameters in different domains, and also of the non-linear progress in the development of attributes that may often be seen through study of the development of design attributes. For example, the pattern of change of turbine inlet temperature for gas turbine engines is characterised by steady improvement using particular blade technologies, with discontinuous change as new blade technologies are developed, as shown in Figure 1.

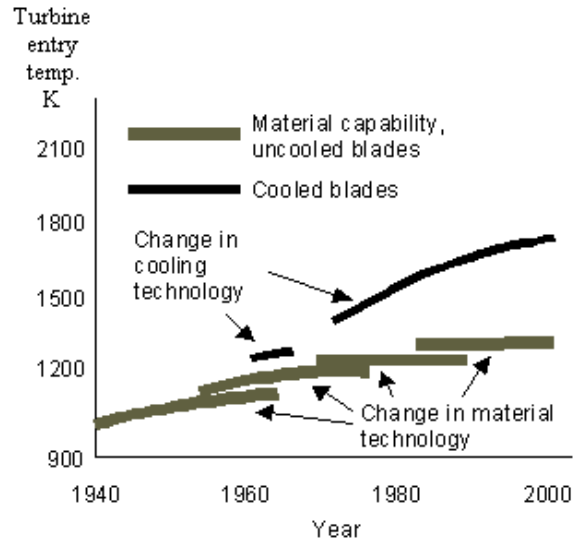

Fig. 1. Variation in Turbine Entry Temperature with Material and Cooling Technology [8]

The relative importance of design attributes is also a strong reflection of the market pressures on the design – for example in the automotive industry there was a change in emphasis from economy to performance between the 1970s and 1980s. From time to time in any design field the established “guidepost” design will be replaced by a new approach that will be so clearly an improvement that it will displace the original preferred design. A good example is the replacement of the gasoline engine by the gas turbine for aircraft propulsion in the 1940s.

### 2.2 Learning in Design

All of the examples described so far involve learning in design. The way in which this learning takes place is the subject of some debate. As noted, for some, designs evolve in a manner that is more or less analogous to biological evolution in response to environmental change [6][7]. Gero [9], describes a schematic model for design in which routine and non-routine design experience is embedded in prototypes – in effect guideposts within sub-domains of design. Vincenti [2] describes the growth of design knowledge in terms of a “blind-variation-and-selective-retention” model in which engineers propose many design changes, and only retain those that work. The changes that do not work often result in failure, and Blockley and Henderson see this as crucial in the growth of knowledge. They describe the growth in terms of the “falsification” of design proposals – conjectures – by failure [10]. Petroski [11] places similar emphasis on the importance of failure in engineering. Sahal [5] described learning as taking place as the scaling of designs is attempted (for example to increase the output of power plant), or by innovation through “creative symbiosis” – the synergetic combination of existing technologies – as prime mechanisms for development.

In many of the learning mechanisms that have been described, learning is centred on understanding the

<sup>1</sup> To some degree, variant design should also be included.

behaviour of artefacts, in particular when they fail or encounter limits in some respect. McMahon proposed [12] that failure takes place when some constraint boundary is crossed, and that designs are improved by improved understanding of the demands and constraints on the design, by overcoming constraints through new technology, or by the incremental or revolutionary adoption of new design approaches at sub-system level. It is this view that will now be presented in the next section.

### 3. MODES OF CHANGE IN DESIGN

In [12], it was suggested that the design of an artefact is driven by the requirements or demands placed upon the artefact by the customer, expressed in some form of design brief or specification. Designs that are proposed to meet these requirements are defined within a design space bounded by constraints, and the design process is one of searching within the bounded design space. The artefact design itself may be described by a data model incorporating design attributes, describing the modelled properties of the design. Two main types of attribute were described: design parameters (called explicit attributes in [12]), that describe the design for subsequent manufacture, typically represented in drawings, diagrams and CAD models; performance parameters<sup>2</sup> (called implicit attributes in [12] because they are implicit in the design if subject to an external environment) that describe the characteristics and behaviour of the artefacts subject to an external environment – represented as a set of “loads”. The behaviour of the artefact is estimated during the design process through analysis and test. Finally, if there is trade-off in the relative importance of different performance parameters, then this may be expressed through a utility function of some sort.

The initial establishment of an accepted design in a given domain is usually the result of a wide examination of alternative approaches. Preferred design approaches may draw together successful features from a number of example designs. Once a guidepost design has been established, there are a number of modes in which it may be developed. These include the following:

**Parameter space exploration.** This mode of design change involves the variation of design parameters within limits defined by constraints on these parameters. This might be done directly by the designers themselves, or it might be carried out by some automated routine, for example as part of an optimisation procedure. Collection of data for design may involve a parametric study of the performance of a component or system, for example as described by Vincenti for the case of aircraft propellers [2].

**Improved understanding of the relationships between design parameters and performance parameters.** Analytical and experimental techniques are used to estimate the performance parameters for a given set of design parameters and load cases. Improved understanding of the relationship between design and performance parameters may allow the effective design space to be increased. The improved understanding may come from experiment, from the application of computer-based analytical techniques, from improved modelling or mathematical methods, from examination of competitive products and so on. For example improved analytical techniques that enable more accurate calculation of stresses in a component may allow lighter parts to be made without violating design constraints.

**Design uncertainty.** In most cases, design is undertaken under conditions of incomplete and uncertain data. Uncertainty will exist in the design parameters, in the load cases to which the artefact will be subjected, and in the estimates of performance parameters. Much of the effort that goes into improving the understanding of design data and design relationships is aimed at reducing uncertainty as well as increasing completeness.

**Change in product design specification.** If market conditions change, this may be reflected in a change in the product design specification, in particular through the following:

- Change in the specified values of performance or design parameters that the design should meet – for example changes in legislation may change the required location of a fender on an automobile (design parameter) or the emissions criteria that an automobile has to meet (performance parameter).
- A change may occur in the utility function for the design. An example of this is the change in emphasis from performance to economy for automobiles and aircraft in the mid-1970s with the energy crisis at that time.
- The set of functional requirements that the design has to meet may be modified. An example is the incorporation of requirements for anti-lock braking into automobile specifications in recent years.

**Modifying the feasible design space.** If the feasible attribute space changes then this may allow improvement in design performance. Examples include changes in a manufacturing process (e.g. change in minimum wall thickness for a casting, or in the maximum size of an extrusion), or of material (such as development of an alloy with improved fatigue performance).

**Changing the design principle.** The final mode of change involves the adoption of an alternative design

<sup>2</sup> Suh [13] uses the terms design parameters and performance parameters

principle. This may of course always be done in the design process, but in practice considerations of design risk may often mean that companies will retain established design configurations for as long as they continue to allow acceptable designs to be produced.

In [12], it was argued that if one studies the historical developments in a particular design domain there will be examples of different modes of change, as the design responds to changes in the environment and to changes in production and materials technologies. Where changes are made in the solution principle for the design, these are often made for the purposes of constraint alleviation: change is made to remove a restriction on further improvement in the design performance. Examples of such changes from the domain of internal combustion engines include:

- The incorporation of steel rings in aluminium pistons for expansion control, or of cast iron ring grooves cast into aluminium pistons in order to achieve greater durability.
- The use of common-rail injection systems in diesel engines to allow greater control over the injection event.
- Incorporation of film cooling in nozzle guide vanes to allow higher gas turbine inlet temperatures to be used.
- Removal of the clapper in gas turbine fan blades to allow improved aerodynamic performance.

### 3.1 Guidelines for design change

The question that a design organisation is faced with when deciding how to allocate its design resource is this: where should design effort be put such that the maximum design performance is obtained? For example, will effort spent in exploring the existing design space with an optimisation algorithm yield a greater improvement in artefact performance for the same expenditure as investment in a new production machine that for example allows a lighter artefact to be manufactured? The task in managing the design process is thus to try to understand, for the engineering activities that may be carried out to improve the design, the relationships

$$\partial(\text{utility}) / \partial(\text{expenditure})$$

and

$$\partial(\text{time to market}) / \partial(\text{expenditure})$$

In these expressions utility is some measure of the overall performance of the design resulting from the activities. Achieving a general understanding of these relationships is difficult, but the following points may assist the design manager.

**Design maturity:** The most appropriate design approach is likely to change as the design matures. For a young design, there will be many aspects in which the design is very sub-optimal, and the required work at this stage will be to establish a broad

understanding of design constraints, failure modes and the like. As the design matures, techniques such as Quality Function Deployment (QFD) [14] may be used to record the relationship between customer requirements and design features, while incremental changes are made through developments in manufacturing processes, materials and analytical and experimental techniques. For a mature design, the design space may be very well defined and difficult to change, and so it may be necessary to use optimisation techniques to achieve improvement in design performance.

**Product domain.** The most appropriate design approach may also vary with the product domain. It is suggested that the design process in different domains is characterised by the dynamic nature of the product domain. For example, in design of integrated circuits the customer demands may change only relatively slowly, as will the solution principles, but the design space changes all the time owing to changes in manufacturing process capability. In the design of racing cars, by contrast, the design must change regularly to reflect changes in regulations, and improved understanding from experimental and analytical work, as well as the pressures of competition.

**Knowledge management.** The ideas of design attributes, relationships, demands, constraints and external environment may form the basis for a formal record of the design information and knowledge pertaining to a given design domain, for example in technical reports, in a company Intranet or ultimately in a knowledge-based engineering system of some sort.

In all these considerations, the key is for the managers of the design process to understand the dynamics of the design domain and the impact that they have on the most appropriate choice of design approach.

## 4. AN EPISTEMOLOGY FOR DESIGN

What has been described in the previous sections concerns the way that a design team may develop its understanding of the characteristics of the artefacts that it designs. The team learn about how the artefact is used, what performance criteria are used to judge a design, and how it interacts with its environment. They identify what the important descriptive characteristics of the artefact should be and how to match these characteristics to the different goals for the artefact. They learn also how to predict or assess derived characteristics at the design stage, or what to test and measure in development and prototype test. This knowledge, and the information on which it is based, is always incomplete and uncertain, and so the community together seeks new or improved knowledge and information to fill the gaps, to reduce

uncertainty and to develop new understanding. In this section the knowledge and information that is developed by the designing communities will be characterised, as will the patterns of development that may be followed.

Ryle distinguished between two different 'types' of knowledge – 'know how' and 'know that' [15]. He noted that learning about a subject primarily involves the accumulation of 'know that' – principally data, facts and information. Learning about, however, does not produce the ability to put 'know that' into practical use (i.e. knowledge as some type of competence notion). This, Ryle argued, calls for 'know how', which does not come through the accumulation of information. Learning how to do something can only be carried out in practice, which explains why the same information (e.g. a manual, book, verbal instructions, etc.) directed at different people (with different backgrounds and experiences) does not result in the same knowledge in each – practice and context shapes the assimilation of information by individuals. To explain this, Polanyi was the first to distinguish between the 'explicit' and the 'tacit' dimensions of knowledge [16]. He suggests that human beings acquire knowledge by actively creating and organising their own experiences – "...we can know more than we can tell". In making the distinction between the tacit and explicit dimensions, Polanyi argues that no amount of explicit knowledge can provide individuals with the tacit (and trying to reduce one to another is not possible). This resembles Ryle's view that 'know that' does not produce 'know how'. These arguments suggest that information is not enough, on its own, to produce actionable knowledge.

Table 1. *A typology of knowledge*

Knowledge Type	Knowledge dimension	Definition	Example
Embedded knowledge	Explicit	Systematic routines, procedures and practices	Company documents on design procedures & sign-off
Encoded knowledge	Explicit	Knowledge represented by signs and symbols in books, manuals and recorded works	Engineering text book on the principles of aerodynamics
Encultured knowledge	A combination of the two	Knowledge from the process of achieving shared understanding.	Personal log-book of experience on design project
Embrained knowledge	Tacit	"Knowledge about" – the ability to work with complex ideas and concepts.	Personal experience of a variety of design projects
Embodied knowledge	Tacit	"Knowledge how" – practical thinking; problem solving.	Personal ability to plan and execute a design project

We can see similar distinction in Blackler's typology of knowledge shown in Table 1 with additions by the authors [17]. In the context of design, it is suggested that encoded knowledge describes that knowledge and information recorded in books, manuals, codes of practice, specifications and so on, together with recorded information concerning materials, manufacturing processes, machine elements and other components and so on. The reports, catalogues and other documents in a company's document archives constitute encoded knowledge. Embedded knowledge is concerned with knowledge and information about the processes used in design – for example the processes of design analysis and assessment and the formal processes of interaction between the participants in the process. These may be documented in codes of practice, design guides and the like, but they will also be embedded in the collective memory of the members of the design community. Encoded and embedded knowledge are both explicit knowledge in Polanyi's terms. Embrained knowledge by contrast describes the implicit or tacit ability of people to work with complex ideas and concepts, and in the context of design may describe the ability to process complex interactions and trade-offs – the ability to build a holistic view on the artefact. Embodied knowledge is also in general tacit (although some of the efforts of Artificial Intelligence seek to make it explicit) and describes the general problem-solving approaches and attitudes of mind found in design. Embodied knowledge also allows the community to know the limits of its knowledge and where it breaks down. Finally, encultured knowledge may describe the implicit "shared memory" [18] that exists in the design community of practice concerning the shared beliefs and values of the community.

## 5. MATCH OF PROCEDURE TO DESIGN TASK

A company's knowledge regarding the processes it uses may range from total ignorance about how they work to a very formal and accurate mathematical models [19]. The classifications previously described give an insight into forms of knowledge, but in a development process, where the body of knowledge of one phase becomes the informational basis of the next phase, and particularly where it is desirable to automate as many routines as possible, a measure of how much knowledge is known about a process or artefact is required. By adapting a metric developed to describe how much was known about an industrial manufacturing process [19], forms of knowledge can be mapped against the ability to influence that process. Eight stages of technological knowledge have been identified with regard to a process from complete ignorance to complete understanding (refer to Figure 2).

Stage	Description	Comment	Typical form of knowledge
1	Complete Ignorance		
2	Awareness	Pure Art	
3	Measure	Pre-technical	
4	Control of the Mean	Scientific Method Possible	
5	Process capability	Local Recipe	
6	Process Characterization	Trade-offs to reduce costs	
7	Know Why	Science	
8	Complete Knowledge	Nirvana	

Fig. 2. Stages of design knowledge

**Stage 1 - Complete Ignorance.** There is no understanding of the process. Variables may be observed but their relevance to the process, if any, is not recognised.

**Stage 2 - Awareness.** The variable is recognised as having an effect on the process. The transition from Stage 1 knowledge to Stage 2 knowledge is often by serendipity and has a strong element of embrained knowledge applied.

**Stage 3 – Measure.** At this stage variables can be measured accurately, but not controlled. If the effect of the variable is important enough the process can be changed to take advantage of or mitigate its effects. Sometimes just being able to measure a variable leads automatically to knowing how to control it.

**Stage 4 – Control of Mean.** It is possible to control the mean level of the variables with some variance. This is important because some variables previously seen as random can now be used as control variables in experiments to quantify their impact on the overall process.

**Stage 5 – Process Capability.** The control of variables is precise enough to allow generic forms to take shape. This stage is characterised by learning to control the input values to the process.

**Stage 6 – Process Characterisation.** The generic form can be fine tuned to reduce costs and change product characteristics. Feedback controls from the output are introduced to modify any stage six variable that is easy to change and has an appreciable effect. To reach this stage controlled experiments are made with the variable at different values to determine its effects.

**Stage 7 – Know Why.** There is a scientific model of the process and how it operates over a broad region including non-linear and interaction effects of this variable with other variables. The process can be

optimised with respect to stage seven variables. The scientific model is sophisticated enough to simulate the process with stage seven variable values never tried empirically.

**Stage 8 – Complete Knowledge.** The complete functional form of the process is known. Process and environment are so well understood that feed forward control can optimise the variables before they cause a degradation of performance. It is never reached in practice but can be approached by studying the process in more and more detail.

In moving between knowledge stages different forms of knowledge become more prominent though there is often an overlap between the stages, and for a particular artefact the design team may be at several different stages at once for different aspects of the artefact.

The importance of being able to assess the knowledge stage of a process is that it determines the best methodology to manage it. Bohn believes that there is a direct relationship between stage of knowledge and degree of procedure required to manage a process, a view supported by the knowledge management literature discussed earlier [19].

Higher stages of knowledge can be managed more formally until they ultimately become automated. Processes with lower stages of knowledge require much more freedom to explore possible design spaces and should be done using a high degree of expertise and little automation.

The diagram in Figure 4 describes this relationship. Along the optimum line is the correct amount of procedure to suit the stage of knowledge. If there is too little knowledge to support procedure development then the efforts will be ineffective. At the other extreme, if there is a lot of knowledge regarding a process, supported by little procedure then the effort is inefficient.

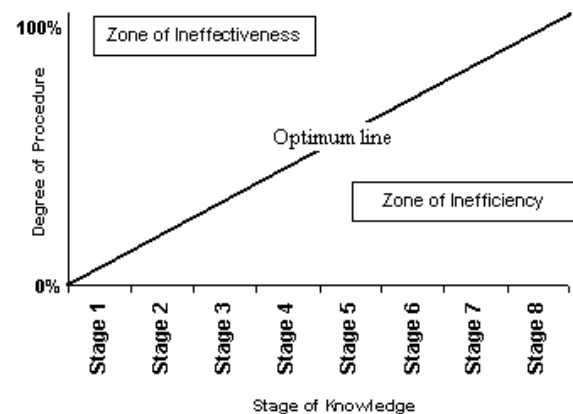

Fig. 3. Ideal operating method and the stage of knowledge

From the model discussed above it is possible to define the CAD modelling techniques in terms of

their abilities to embed and encode procedural routines. Figure 4 shows a suggested mapping, based on aircraft design.

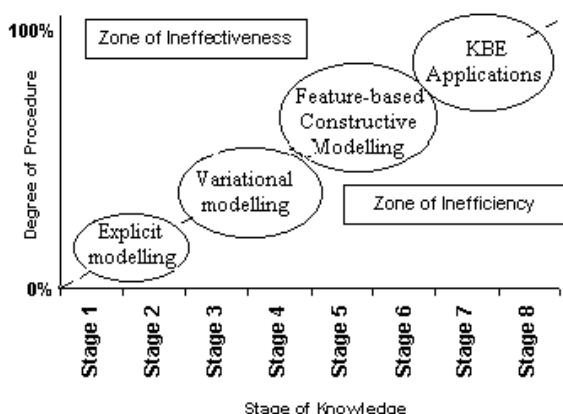

Fig. 4. Mapping CAD modelling methodology to stage of knowledge

Aircraft are similar to cars and ships in having very complex shapes. However they are unique in having a stressed semi-monocoque structure, the structural performance of which is affected by geometry variations between different aircraft. Therefore even mature design solutions must be evaluated in terms of structural integrity and manufacturability [20] in light of the differing geometry. When approaching a completely new aircraft design it should be assumed that the stage of knowledge is between 1 and 3 in all but the most basic structures. Explicit modelling (i.e. modelling using a computer-aided design system in which the product geometry is modelled explicitly rather than in the form of parameterised geometry) is the most flexible methodology to use in these stages to have the freedom to gain experience on the geometric peculiarities of the particular design and to produce initial schemes.

As the design progresses it may become evident that the design solution has a generic form and will only change parametrically with design iterations. How generic that form is and the number of instances and/or design iterations that will be explored will enable the engineer to decide whether to adopt variational, feature-based, or knowledge-based engineering modelling techniques [21]. Variational modelling (in which the design geometry is parameterised such that variations in the geometry whilst retaining the same basic form and topology may be produced easily) is of use when a static design stage has been reached and only a few parameters will be varied, e.g. rib flange or web thickness (Stages 4 and 6). When a design solution is based on a very definite design template, e.g. wing skin stringers (in stages 5 to 8), feature-based modelling (in which the design is assembled from a series of features - building blocks with engineering meaning) is very powerful, and allows for rapid automation. The main differentiation between the variational and feature-based approaches and a KBE application will be the complexity of the relationships governing the differing

variables that need to be managed. As the number of input and output dependencies of the design increase the desirability to automate these data exchanges also increases, justifying the investment in the development of a more automated procedure. An example of design elements for which a KBE solution has been adopted is the aircraft wing stringer, a large number of which are used to attach the skin of the wing to the ribs and spars forming the main structural members. Figure 5 shows a simplified representation of elements of stringers.

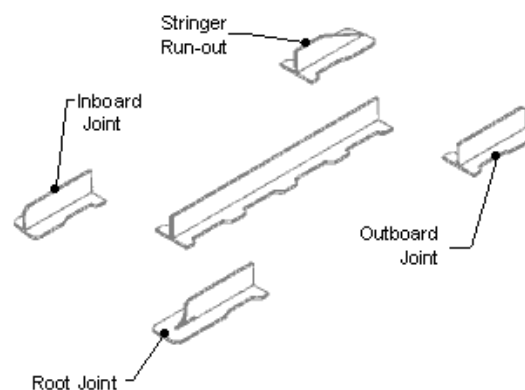

Fig. 5. Elements of aircraft stringers.

There are very many joints between the stringers and other wing members, and the joints differ between stringers and between the root and tip of the wing, such that the design task in designing all of the stringers for a wing is very large. By embedding the rules describing the design of stringers and their joints in a KBE program, much of this design work can be extensively automated.

There are many other very well understood aspects of aircraft design to which the highly procedural KBE techniques may be applied. Equally, there are many areas for which the design knowledge is insufficiently developed for such an approach, and for less procedural modelling techniques to be applied. To fully exploit this classification system to support the design development process efficiently and effectively, an analysis of the complete design life cycle of a component would be necessary to assign the most effective tools.

## 6. CONCLUSIONS

This paper has presented two views on the nature of design knowledge in adaptive design - the approach taken in the majority of design situations. In the first, it is contended that those managing the design process should think of the design challenge in terms of the relationships between the constraints on the artefacts and the demands driving its development, and between design parameters, performance parameters and external environment. The dynamics of these relationships will characterise much of design. The second view is that as design knowledge develops in a particular domain, then the degree to which

procedure may be used in developing the design will change. Only for those design domains that are very well defined – in which the state of knowledge is highly advanced and thus the design configuration is likely to change only slowly – is it likely that tools such as knowledge-based engineering and feature-based design will be most cost-effective.

### Acknowledgements

The authors are grateful for comments on aspects of this work from their colleagues in the Design Information Group at the University of Bristol.

### References

- [1] Pugh, S, *Total Design*, Addison-Wesley, Wokingham, 1990
- [2] Vincenti, W.G., *What Engineers Know and How They Know It*, John Hopkins University Press, Baltimore, MD, 1990
- [3] Constant, E.W., *The Origins of the Turbojet Revolution*, Johns Hopkins University Press, Baltimore, MD, 1980
- [4] Pahl, G and Beitz, W, *Engineering Design*, The Design Council/Springer Verlag, London, 1984
- [5] Sahal, D, *Patterns of Technological Innovation*, Addison Wesley, Reading, MA, 1981
- [6] Businaro, U. L., *Applying the Biological Evolution Metaphor to Technological Evolution*, in: Freeman, C., (Ed), *Design, Innovation and Long Cycles in Economic Development*, F Pinter, London, 1984, pp.104-120
- [7] Nelson, R. R. *Understanding Technical Change as an Evolutionary Process*, North Holland, Amsterdam, 1987
- [8] Robins, Sir Ralph, *Enterprise and innovation*, Aerospace, Vol.21, 1994, pp8-13
- [9] Gero, J. S., *Design Prototypes, a Knowledge Representation Schema for Design*, AI Magazine, Vol.11, 1990, pp.26-36
- [10] Blockley, D. I. and Henderson, J. R., *Structural Failures and the Growth of Engineering Knowledge*, Proceedings of the Institution of Civil Engineers, Vol.68, 1980, pp.719-728
- [11] Petroski, H, *To Engineer Is Human: The Role of Failure in Successful Design*, St Martins Press, New York, 1985
- [12] McMahon, C A, *Observations on Modes of Incremental Change in Design*, Journal of Engineering Design, Vol. 5, 1994, pp.195-209
- [13] Suh, N P, *The Principles of Design*, Oxford University Press, New York, 1990
- [14] Revelle, J., Cox, C.A., Moran, J.W. Kemerling, R.A., *The QFD Handbook*, John Wiley and Sons, Chichester, 1998
- [15] Ryle, G., *The Concept of the Mind*, University of Chicago Press, Chicago, 1949
- [16] Polyani, M., *The Tacit Dimension*, Routledge & Kaufman Paul, London, 1966
- [17] Blackler, F., *Knowledge, Knowledge Work and Organizations: an Overview and Interpretation*. Organization Studies, Vol.16, 1995, pp.1021-1046
- [18] Konda, S., Monarch, I., Sargent, P. and Subrahmanian, E., *Shared Memory in Design: A Unifying Theme for Research and Practice*, Research in Engineering Design, Vol.4, 1992, pp.23-42
- [19] Bohn, R.E., *Measuring and Managing Technological Knowledge*. Sloan Management Review, 1994(Fall).
- [20] Niu, M.C.Y., *Airframe Structural Design*. Technical Book Company, Los Angeles, CA, 1988
- [21] McMahon, C. A. and Browne, J, *CADCAM: Principles, Practice and Manufacturing Management*, Addison Wesley Longman, 1998