

PROPERTIES, APPLICATION AND TRENDS OF DEVELOPMENT OF THIN LAYER – SUBSTRATE SYSTEM

J. Koutský, I. Štěpánek, A. Kříž

Keywords: surface engineering, nanohardness, scratchtest, step by step tests, tribological tests, sandwich and multilayers, deposition parameters.

1. Introduction

Thin layers are broadly used in technical applications like microelectronics, electrotechnics optics, machinery, automobile and air industry, chemical industry, etc. For all applications is necessary to optimize properties of originated layer, and therefore to find the optimum technology and optimum deposition parameters. With respect to manyparametric system, with complicated inner bonds the experimental optimization is very difficult. Therefore theoretical models and descriptions of running processes are permanently developed, improved and experimentally verified.

Ceramics, with high hardness, corrosion resistance, and thermal resistance is mostly used as a material of thin layer. High brittleness of ceramic material is compensated by strength and toughness of basic material (steel or sintered carbides).

Thin layers – substrate system (L-S) has to be mentioned as a nondivisible component including many parameters mutually acting. With the development of new materials it is necessary to develop new methods of evaluation. Further development of methods must include as well laboratory and operation tests as laboratory-operation tests, that are able to describe the relations between deposition process parameters, basic mechanical, corrosion and thermal properties, properties including the combination of some contemporal influences and parameters simulating operation conditions. The development of new evaluation methods and programming tests of basic and combined properties of thin layer-substrate system should be supported.

Gradient layers and multilayers are favorized in last stage for application. It is more necessary to enforce the development of new evaluation methods.

Methods of step by step evaluation of combined loading and evaluation method by test of laboratory contemporal loading should be basic stones for complex method of combined loading evaluation.

2. Deposition of thin layer

Deposition of thin layers is classified followly:

- a) physical methods PVD (physical vapor deposition) – material atoms are product of physical methods – evaporation or sputtering.

- b) Chemical methods CVD (chemical vapor deposition) – reactive components are delivered in gas phase and the layer is formed on the surface of substrate by heterogeneous reaction at high temperature.

2.1 Arc evaporation

Arc evaporation method belongs to the physical deposition methods using globe charge plasma. Evaporation of metal from electrode by using electric arc is possible by two manner:

- Anode evaporation
- Catode evaporation

Arc discharge is an independent discharge at the current higher than $1 \div 10A$ characterized by:

Low voltage near the value of gas or ionized metal potential
High current density on the catode surface
High concentration of particles in catode area

Depositon process can be divided as follows:

Creation of material vapors passing in the source area
Particles transport from source to substrate
Creation of layer, it happens on the substrate surface

Main factors decisively influencing initiation and growth of layer are the substrate temperature, its chemical composition, cleanness and roughness of surface and energy and concentration of incidenting particles. The whole phase of layer growth and its micro-macroscopic properties are influenced by these factors.

The microstructure, including shape and dimension of layer crystalits, defects density, pores presence, etc.

At low energy and ionization of impinging particles the microstructure of created polycrystalline layer is given by substrate temperature T_s , homologic temperature T_s/T_m , where T_m is the melt temperature of layer material. Characteristic properties of layer microstructure exist, cohering only with T_s/T_m (fig. 1).

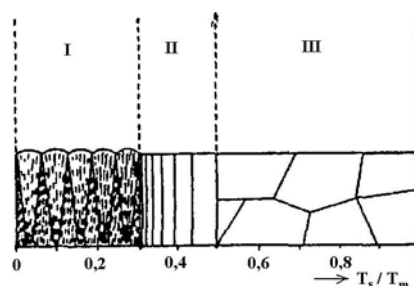

Figure 1. Structure mode of Movčan-Demčičin

3. Deposition conditions optimalization

PVD method of low-voltage reactive evaporation is used in our department for creation of thin layers on deposition equipment NNO 150 (fig. 2).

Deposition of binary nitride layers is optimized for different basic materials (predominantly high-speed steels 19 802, 19 830, 19 852, 19 856).

Chemical cleaning is an important part of deposition process. Its target is to remove organic and anorganic impurities-strongly influencing the process of interface forming between the layer and substrate and the growth process of thin layers on the substrate surface.

Very important part of deposition process is ion bombard process. First ion bombard target is completing of substrate surface cleaning after chemical cleaning before deposition process. Second ion bombard target is creation of suitable interface between thin layer and basic material. Third ion bombard target is delivering of energy into the system and interface layers creation between basic material and thin layer in dependence ion complex conditions of deposition process.

Fourth ion bombard target is heating of specimens, items, parts, etc. prepared for deposition of thin layers to deposition temperature and keeping substrate on this temperature through the whole deposition process.

Substrate heating process to deposition temperature by help of accelerated ions impact is an important part of ion bombard. Heat rate is strongly changed in dependence on geometric structure of substrate as well as on its shape and mass.

Deposition conditions optimalization is concentrated on macro- and microparameters controlling which are not simply controllable, but their values are either stabilized or going change during deposition process operation and are not easily recordable by measuring apparatus.

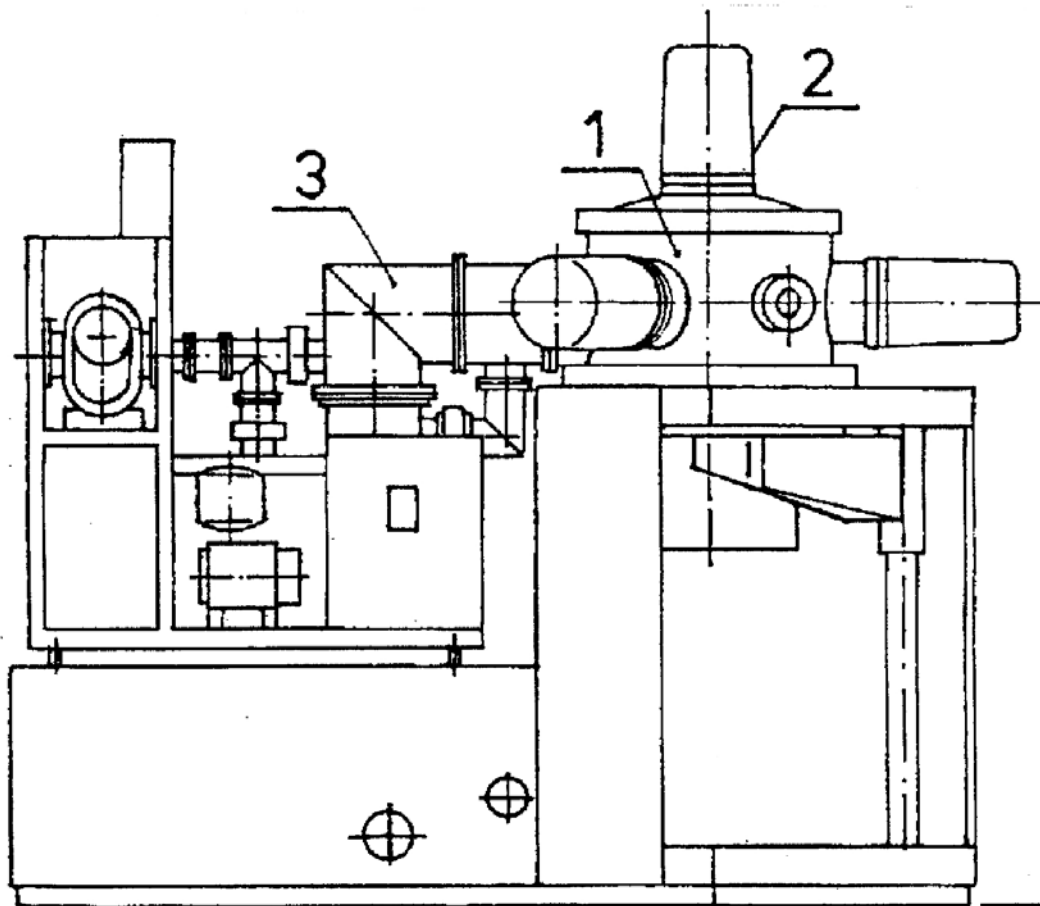

Figure 2. Schema of deposition device NNO 150 150

vacuum chamber, 2 – vaporizer, 3 – pumpin system

4. Thin layer evaluation

Thin layers used for life improvement of machine parts in operation loaded by combination of mechanical, thermal and chemical influences. Therefore the tests of thin layers and systems with thin layers are orientated on investigation of mechanical, thermal and corrosion properties and their behavior in these conditions. Mechanical properties of thin layers and systems with thin layers include static indentation tests, notch tests, friction tests, contact fatigue tests, etc.

Layer thickness is measured by calotest method or it is possible to determine it from depth profile measured by GDOES method. This method is often used for substrate element composition determination.

4.1 Mechanical properties evaluation by help of nanoindenter

Microhardness measurement is the basic mechanical test for coated materials, investigating material resistance against local plastic deformation, that appears below penetrating body (nanoindenter) during its loading. Measurements are usually provided at indenter load less than 200g on microhardness testers, that are bound with optical microscope for indenter volume investigation. Interpretation of results of this simple test brings some problems because measured values of microhardness are influenced by a set of problems (human, apparatus, material factors), especially at low loads.

Nanoindentors registrate at measuring s:c indentation curve (fig. 3) what are dependences of indenter penetration depth h on indenter loading greatness L at its loading and deloading. Knowing precise shape of indenter it is possible to calculate from the indenter penetration depth the magnitude of indenter area A and afterwards the value indicated as nanohardness or dynamic hardness.

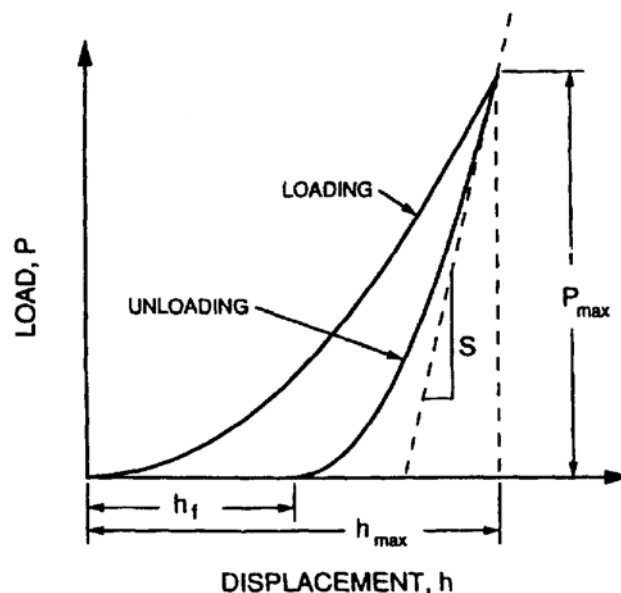

Figure 3. Indentation curve of elastic-plastic material

4.2 Adhesive-cohesive behavior of thin layer-substrate by help of penetration methods

Methods of evaluation of adhesive-cohesive behavior of thin layer-substrate system are based on indenter generated stress on the interface of this system. Stress necessary for overcoming of bonds between layer and substrate at static indenter penetration is investigated.

Penetration methods are divided into two groups: 1) following of crack dimensions initiated at the edge of indenter body loaded by constant force; 2) crack initiation investigation in dependence on indenter loading value.

By the first method cracks dimensions initiated on the interface evocated by static penetration test are investigated.

In fig. 3 the method of individual indentors is divided in individual classes with addition of adhesive number HF, characterizing step of cracking or layer spalling.

4.3 Corrosion tests

Corrosion resistant examination tests can be divided:

- Long time tests in operation conditions
- Laboratory tests of shorter prolongation
- Accelerated laboratory tests
- Non direct corrosion tests

To decide what type of corrosion should be elected the following acces is possible:

- Research lines of sight
- Current tasks of corrosion testing
- Research and development lines of sight
- Manufacture quality control

4.4 Thermal resistance tests

Tests groups according to kinds of found out properties:

- Temperature influence on structure changes tests
- Temperature influence on mechanical properties changes tests
- Time dependence of surface state at thermal loading
- High temperature resistance tests

4.5 Step by step evaluation of combined loading

Step by step evaluation is based on variable loading of specimen surface by individual kinds of loading. The whole procedure is schematically expressed in fig. 4.

Individual step of combined loading are alternatively or cyclicly applied on specimen surface. Evaluation of every loading step is carried out by nondestructive methods.

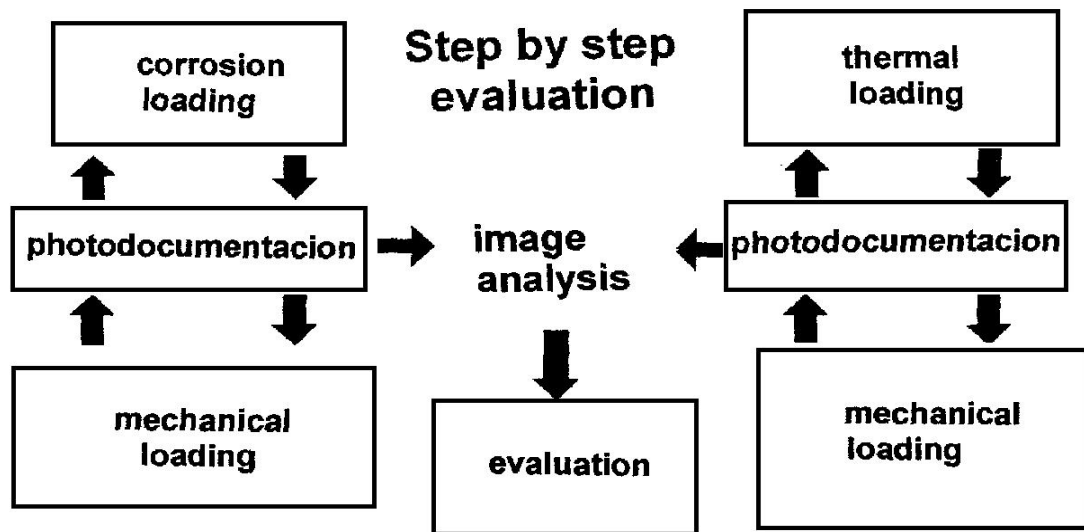

Figure 4. Step by step evaluation

4.5.1 Step of mechanical loading

Rockwell diamond tip is mostly used for simulation of mechanical loading. On the edge of the scratch cracks are appearing in the layer and in the L-S interface. According to the character and magnitude of cracks it is possible to correlate the degree of adhesive or cohesive deterioration. Abrasive friction is evaluated by calotest. Calottes bring informations about adhesive-cohesive behaviour in different depths below thin layer system surface and resistance against abrasion.

4.5.2 Step of corrosion loading

At corrosion cycle specimen surface is exposed to the effect of corrosion environment for determinated time. Corrosion medium and acting time of agent is choosen in dependence on material type with respect to its inclination to fixed corrosion types, expected corrosion rate and corrosion condition in practical application of tested thin layer system.

4.5.3 Step of thermal loading

During thermal cycle a specimen is exposed to the determinated temperature for a fixed time. Acting time and loading temperature are given with respect to assumed thermal loading of system with thin layer in practical conditions, phase transfer temperatures coefficients of thermal dilatations of individual components of thin layer system.

5. Trends of thin layer research and application

In mechanical engineering the deposition of thin wear resistant layers of different metallic nitride types is mostly carried out on cutting, forming tools and strongly loaded machine parts. A thin hard nitride coating enhances the tool lifetime of cutting tools due not only to its tribological properties but also because it considerably reduces the mechanical and heat-related wear of the substrate. Thanks to this, cutting edges equipped with this thin layer can remain in operation much longer than cutting tools without the special coating. Apart from the already mentioned qualities, improvement in cutting edges durability is made possible by a greater resistance against abrasive wear. The thin layer, forming a compact unit with the cutting tool must by means of its chemical stability maintain a high quality diffuse barrier.

The system characteristics are also dependent on its adhesive-cohesion behavior. The demands on the thin coating are especially high considering the need of unchanged output even in high temperatures, which occur in the cutting process. Individual types of the usual binary nitrides meet these requirements only partially. To reach the best results, it is necessary to combine coatings of conventional binary nitrides of titanium (TiN) with modern coatings based on TiAlN. These coatings are designed either in a sandwich-like setting or in a multi-layer arrangement, where individual layers alternate periodically. Adding silicon to enrich the thin layer material considerably improves the compact character there of, which then heightens the hardness and heat stability of the material.

Finegrained onephase layers TiC, TiN, Al₂O₃ are less applied. The need to connect positive properties of individual layers is a reason for formation of manylayers application. The sequence of queing corresponds to their properties and their transition is sharply limited (fig. 5). Firstly the layers with better adhesion are deposited on the substrate. Their wear resistance is relatively lower. Last layer is characterized by its hardness, wear resistance, resp. its friction properties. Following thin layers are now applied in practice: TiC - Al₂O₃; TiN - Ti (C, N); TiN - TiC - TiN. The whole depth of these layers is 3 ÷ 5 μm and reaches 35 - 40 GPa hardness.

Many layers system consisted of up 15 parts started to be examined: TiC - TiN - TiC - TiN - TiC - Al (O, N) - TiN - Al (O, N) - TiN - Al (O, N) - TiN - Al (O, N) - TiN.

The development of new layers follows mostly the road of multilayers systems (fig. 6), reaching very high hardness and excellent adhesion. Different layers types with different physical properties are periodically alternated of individual layers not wxceed 10 nm. Progressive multilayer systems reach up to 2,5 nm value (f. e. multilayer TiN - AlN [8] - composed of 2000 alternating layers on tool surface).

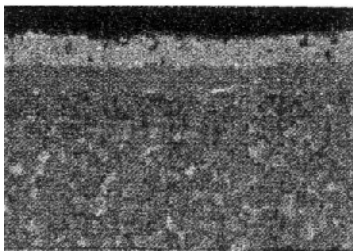

Figure 5. Many layers system

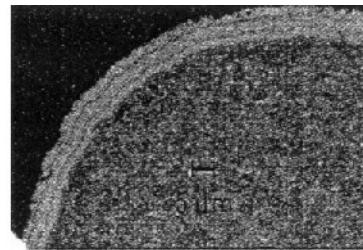

Figure 6. Multilayer system

Tribological properties mostly approach to the practical application; therefore wear resistant tests should be theoretically as well as experimentally developed and studied. Tribological tests are concentrated on determination of friction coefficient its change during examination of two materials combination, substrate and corpuscle of specific properties and dimensions. Methods of tribological properties investigation can be divided according to mutual movement of investigated material and acting corpuscle, and geometric shape of corpuscle. One of the very often applied method is Pin on Disk Test.

In spite of big successes of deposition technologies their verification is enough expensive. Up till now physical and physical-chemical nature of deposition processes was not fully clarified and the influence of deposition parameters, basic material and material of layer on final properties of created system was not sufficiently defined and the verification of deposition technology needs many experiments.

The development of new technology requires to dispose with diagnostic means and methods for studying not only layers, resp. substrate, but also basic parameters of deposition process.

References

- Jílek, M., Holubář, P., "Zkušenosti s použitím PVD vrstev na nástrojích ze slinutých karbidů", *Seminář technologů a výrobců nářadí II*. Brno, 1999.
- Příručka obrábění. Kniha pro praktiky. Sandvik CZ, 1997.
- Houdek, J., "Frézy a frézování", *Průmyslové spektrum* 5/1998.
- Musil, J., Vyskočil, J., "Tenké vrstvy nitridů titanu", 1989, 181 s.
- Obrábění grafitu nástroji s povlaky diamantu. *Technik* 4/1998.
- Kvasnička, I., "Řezné materiály pro obráběcí nástroje", *Technik* 2/1998.
- Humár, A., "Slinuté karbidy a řezná keramika pro obrábění", 1995, 265 s.
- Marek, M., "Povlaky nástrojů", *Průmyslové spektrum* 9/1998.
- Jareš, V., "Mechanické zkoušení kovů", 1955, 58 s.
- Kříž, A., "Vlastnosti řezných nástrojů s tenkými vrstvami TiN, ZrN", *Disertační práce*, 1998, 164 s.
- Píšek, F., "Nauka o materiálu II", 1. svazek, 1959, 660 s.
- Němec, R., "Nanoindentační měření v mikrolokalitách tenkých vrstev či povrchů", *Diplomová práce*, 1999, 86 s.
- Holmberg, K., Matthews, A., "Coatings Tribology; Properties, Techniques and Applications in Surface Engineering", 1994, 442 s.
- Štěpánek, I., Bláhová, O., Kolega, M., "Tenké vrstvy-vytváření, vlastnosti", 1994, 110 s.
- Sekler, J., Steinmann, P.A., Hintermann, H.E., "Surface and Coatings Technology", 36, 1988, 519 s.
- Iliuc, I., "Tribology of Thin Layers", 1980, 225 s.
- Dobrzanski, L.A., Kříž, A., Kwasny, W., "XXVII szkola inzynierii materialowej", Krakov, 2000, 421-424 s.
- "Pin on Disk Friction Test", http://ccm.cn.purdue.edu/tfd/testing_methods/pin_on_disk.htm
- "Principle Pin-On-Disk, Disk-On-Disk, Ball-On-Disk", ASMT G 133. <http://www.wazau.de/tribometl.htm>
- Kříž, A. "Povrchové změny systému tenká vrstva-substrát po tepelném zatížení" 18. dny tepelného zpracování s mezinárodní účastí. Brno, 2000.

Prof. DrSc. Ing. Jaroslav Koutský
University of West Bohemia, Department of Material Science and Technology,
Univerzitní 22, Plzeň 306 14 , Czech Republic